

MONOLITHIC AMPLIFIERS

50Ω

BROADBAND DC to 8 GHz

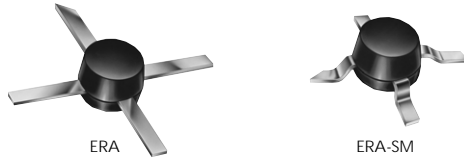

+ RoHS compliant in accordance with EU Directive (2002/95/EC)

The + suffix identifies RoHS Compliance. See our web site for RoHS Compliance methodologies and qualifications.

low power, up to +13.5 dBm output

all specifications at 25°C

MODEL NO.	FREQ. GHz f _l - f _u	GAIN, dB Typical							MAXIMUM POWER (dBm) at 2 GHz*		DYNAMIC RANGE at 2 GHz*		VSWR (:1) Typ.		ABSOLUTE MAX. RATING ³		DC OPERATING POWER ⁴ at Pin 3			THERMAL RESISTANCE	CASE STYLE	CONNECTION	PRICE \$					
		over frequency, GHz							Output (1 dB Comp) Typ.	Input (no dmg) Min.	NF (dB) Typ.	IP3 (dBm) Typ.	In DC-3 GHz	Out 3-f _u ** DC-3 GHz	I (mA)	P (mW)	Device Volt.			θ _{jc} Typ. °C/W	Note B							
		0.1	1	2	3	4	6	8									Min. @ 2 GHz	Typ.	Min.					Typ.	Typ.	Typ.	Min	Max
ERA-1(+)	DC-8	12.3	12.1	11.8	10.9	9.7	7.9	8.2	9	12.0	10.0	15	4.3	26	1.5	1.8	1.5	1.9	75	330	40	3.4	3.0	4.1	178	VV105	cb	1.37
ERA-2(+)	DC-6	16.2	15.8	15.2	14.4	13.1	11.2	—	13	13.0	11.0	15	4.0	26	1.3	1.4	1.2	1.6	75	330	40	3.4	3.0	4.1	155	VV105	cb	1.52
ERA-3(+)	DC-3	22.1	21.0	18.7	16.8	—	—	—	16	12.5	9	13	3.5	25	1.5	—	1.4	—	75	330	35	3.2	3.0	4.1	154	VV105	cb	1.67
ERA-1SM(+)	DC-8	12.3	12.1	11.8	10.9	9.7	7.9	8.2	9	12.0	10.0	15	4.3	26	1.5	1.8	1.5	1.9	75	330	40	3.4	3.0	4.1	183	WW107	cb	1.42
ERA-21SM(+)	DC-8	14.2	13.9	13.2	12.2	10.8	8.7	8.9	11.2	12.6	10.6	15	4.7	26	1.1	1.4	1.3	1.9	75	330	40	3.5	3.0	4.1	194	WW107	cb	1.57
ERA-2SM(+)	DC-6	16.2	15.8	15.2	14.4	13.1	11.2	—	13	13.0	11.0	15	4.0	26	1.3	1.4	1.2	1.6	75	330	40	3.4	3.0	4.1	160	WW107	cb	1.57
ERA-33SM(+)	DC-3	19.3	18.7	17.4	15.9	—	—	—	15	13.5	11.5	13	3.9	28.5	1.6	—	1.25	—	75	330	40	4.3	3.8	4.8	140	WW107	cb	1.72
ERA-3SM(+)	DC-3	22.1	21.0	18.7	16.8	—	—	—	16	12.5	9	13	3.5	25	1.5	—	1.4	—	75	330	35	3.2	3.0	4.1	186	WW107	cb	1.72

features

- for RoHS compliant version, add + to model prefix
- low thermal resistance
- miniature microwave amplifier
- available in drop-in & surface mount (sm) versions
- frequency range, DC to 8 GHz, usable to 10 GHz
- up to 18.5 dBm typ. (16.5 dBm min) output power

model identification

Model	marking (see note below)	demo board
ERA-1, ERA-1SM(+)	1	ERA-01TB
ERA-2, ERA-2SM(+)	2	ERA-02TB
ERA-21SM(+)	21	ERA-21TB
ERA-3, ERA-3SM(+)	3	ERA-03TB
ERA-33SM(+)	33	ERA-33TB
ERA-4, ERA-4SM(+)	4	ERA-04TB
ERA-5, ERA-5SM(+)	E5	ERA-05TB
ERA-50SM(+)	50	ERA-50TB
ERA-51SM(+)	51	ERA-51TB
ERA-6, ERA-6SM(+)	6	ERA-06TB

Note: Prefix letter (optional) designates assembly location. Suffix letters (optional) are for wafer identification.

absolute maximum ratings

- operating temperature: -45°C to 85°C
- storage temperature: -65° to 150°C

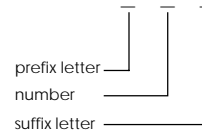

NOTES:

- ◆ Aqueous washable
- * at 1 GHz for ERA-4,5,6, 4SM, 5SM, 50SM, 51SM, 6SM
- ** f_u is the upper frequency limit for each model as shown in the table.
- † Gain and VSWR are specified at 1.5 GHz.
- ⊛ Low frequency cutoff determined by external coupling capacitors.
- A. Environmental specifications and re-flow soldering information available in General Information Section.
- B. Units are non-hermetic unless otherwise noted. For details on case dimensions & finishes see "Case Styles & Outline Drawings".
- C. Prices and Specifications subject to change without notice.
- D. For Quality Control Procedures see Table of Contents, Section 0, "Mini-Circuits Guarantees Quality" article. For Environmental Specifications see Amplifier Selection Guide.
1. Model number designated by alphanumeric code marking.
2. ERA-SM models available on tape and reel.
3. Permanent damage may occur if any of these limits are exceeded. These ratings are not intended for continuous normal operation.
4. Reliability predictions and normal operating conditions are applicable at current specified.

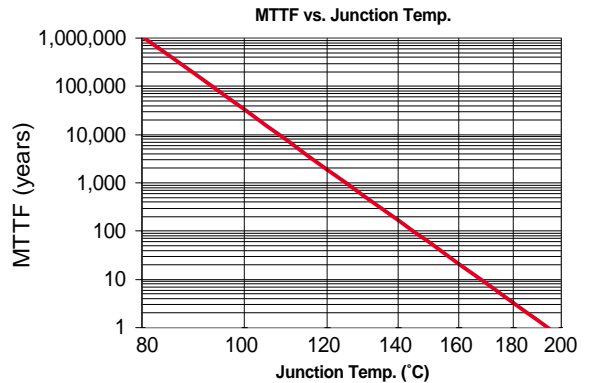

Drop-In & Surface Mount

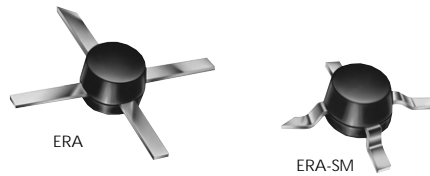

medium power, up to +18.4 dBm output

all specifications at 25°C

MODEL NO.	FREQ. GHz $f_i - f_o$	GAIN, dB Typical							MAXIMUM POWER (dBm) at 2 GHz*		DYNAMIC RANGE at 2 GHz*		VSWR (:1) Typ.				ABSOLUTE MAX. RATING ³		DC OPERATING POWER ⁴ at Pin 3			THERMAL RESISTANCE	CASE STYLE	CONNECTION	PRICE \$			
		over frequency, GHz							Output (1 dB Comp.) Typ.	Input (no dmg) Typ.	NF (dB) Typ.	IP3 (dBm) Typ.	In DC-3 GHz	3-f _u ** 3-f _u **	Out DC-3 3-f _u **	I (mA)	P (mW)	Current (mA)	Device Volt. Min	Max	θ _{jc} Typ. °C/W	Note B		Qty. (30)				
		0.1	1	2	3	4	6	8	Min. @ 2 GHz																			
ERA-6(+)	DC-4	12.6	12.5	12.2	11.7	11.3	—	—	10.5	17.9	16	20	4.5	36	1.3	1.2	1.6	1.8	120	650	70	5.0	4.6	5.6	170	VV105	cb	3.85
ERA-4(+)	DC-4	14.3	14.0	13.4	12.7	11.8	—	—	11	17.3	15	20	4.2	34	1.2	1.2	1.3	1.8	120	650	65	4.5	4.2	5.5	163	VV105	cb	3.85
ERA-5(+)	DC-4	20.2	19.5	18.5	16.7	14.3	—	—	16	18.4	16.5	13	4.3	32.5	1.3	1.3	1.2	1.3	120	650	65	4.9	4.2	5.5	133	VV105	cb	3.85
ERA-6SM(+)	DC-4	12.6	12.5	12.2	11.7	11.3	—	—	10.5	17.9	16	20	4.5	36	1.3	1.2	1.6	1.8	120	650	70	5.0	4.6	5.6	143	WW107	cb	3.90
ERA-4SM(+)	DC-4	14.3	14.0	13.4	12.7	11.8	—	—	11	17.3	15	20	4.2	34	1.2	1.2	1.3	1.8	120	650	65	4.5	4.2	5.5	196	WW107	cb	3.90
ERA-51SM(+)	DC-4	18.0	17.4	16.1	14.8	12.5	—	—	14	18.1	16.5	13	4.1	33	1.1	1.2	1.2	1.9	120	650	65	4.5	4.2	5.5	154	WW107	cb	3.90
ERA-5SM(+)	DC-4	20.2	19.5	17.6	15.6	14.0	—	—	16	18.4	16.5	13	4.3	32.5	1.3	1.3	1.2	1.3	120	650	65	4.9	4.2	5.5	133	WW107	cb	3.90
† ERA-50SM(+)	DC-1.5	20.7	19.4	18.3	—	—	—	—	16	17.2	16.0	13	3.5	32.5	1.3	—	1.2	—	120	650	60	4.4	4.0	4.9	177	WW107	cb	2.95

typical biasing configuration

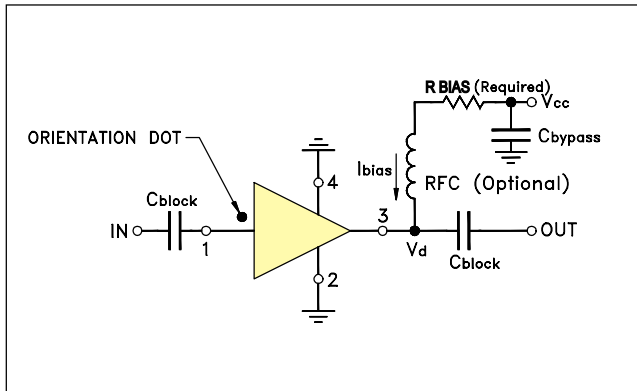

R BIAS									
"1%" Resistor Values (ohms) for Optimum Biasing of ERA models									
Vcc	ERA-1, -1SM	ERA-2, -2SM	ERA-21SM	ERA-3, -3SM	ERA-33SM	ERA-4, -4SM	ERA-5, -5SM	ERA-50SM, -51SM	ERA-6, -6SM
7	90.9	88.7	88.7	107	69.8	38.3	33.2	40.2	30.1
8	113	113	113	133	93.1	52.3	48.7	53.6	43.2
9	137	137	137	162	115	66.5	63.4	68.1	56.2
10	162	162	162	191	140	80.6	78.7	82.5	69.8
11	187	187	187	221	165	95.3	95.3	97.6	84.5
12	215	215	210	249	191	110	110	113	97.6
13	237	237	237	280	215	127	124	127	113
14	261	261	261	309	243	143	140	143	127
15	287	287	287	340	267	158	158	158	140
16	309	316	316	365	287	174	174	174	154
17	332	340	340	392	316	187	187	191	169
18	357	365	365	422	340	205	205	205	182
19	383	392	392	453	365	221	221	221	196
20	412	412	412	475	392	237	232	237	210

designers kits available

KIT NO.	Model Type	No. of Units in Kit	Description	Price \$ per kit
K1-ERA	ERA	30	10 of each 1,2,3	49.95
K2-ERA	ERA	20	10 of each 4,5	69.95
K1-ERASM	ERA-SM	30	10 of each 1SM, 2SM,3SM	49.95
K2-ERASM	ERA-SM	20	10 of each 4SM, 5SM	69.95
K3-ERASM	ERA-SM	30	10 of each 4SM, 5SM, 6SM	99.95

pin connections

PORT	cb
RF IN	1
RF OUT	3
DC	3
CASE GND	2,4
NOT USED	—

NSN GUIDE

MCL NO.	NSN
ERA-1SM	5962-01-459-9075
ERA-2SM	5962-01-459-7410
ERA-5SM	5962-01-459-9314